

F7 Draw Latch

Flexible · Pull type

Features

- Flexible one piece molded latch
- UV resistant
- Absorbs and reduces vibration

Product Performance

- Clamping force
 - Small: 58 N
 - Medium: 84 N
 - Large: 98 N
- Flammability rating: UL94-HB

Material

- Thermoplastic elastomer and glass-filled nylon, black
- Screw: Stainless steel, passivated

Installation Notes

- Concealed:
 - Install assembly with thread forming screws (order separately)
 - Maximum tightening torque 2.0 N.m
- Front installation:
 - Install assembly with M5 screw or Ø5 rivet (not supplied)

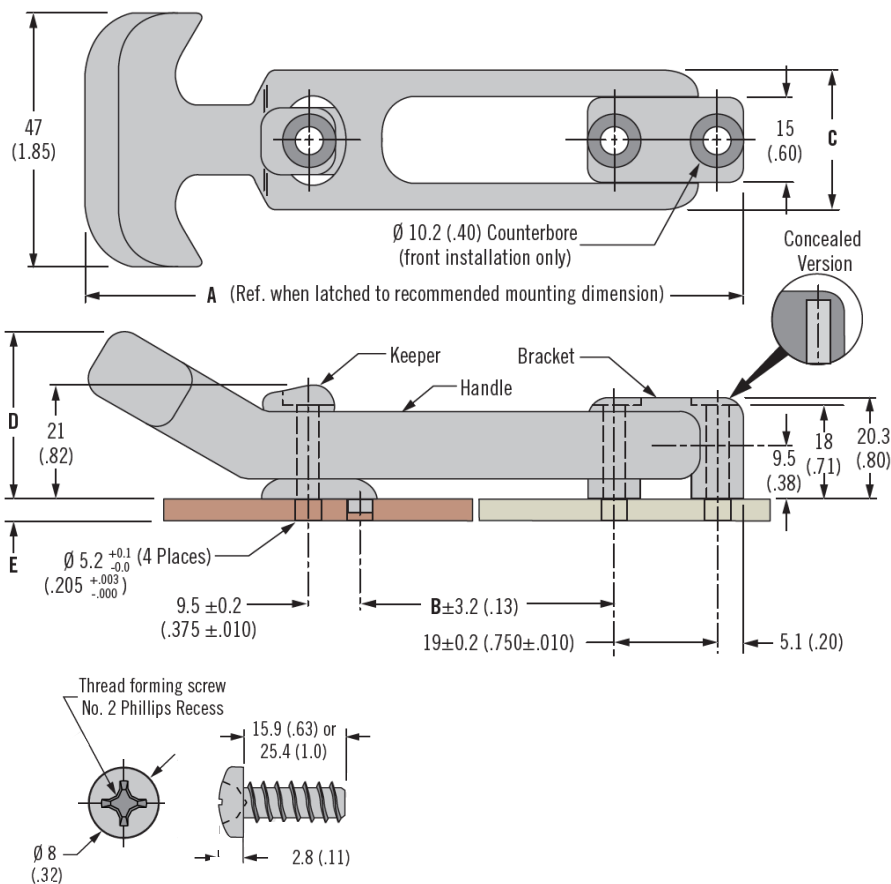

Part Number				Installation Method	Dimensions				
Size	Latch	Keeper	Screws (3 per bag)		E	A	B	C	D
Small	F7-530	F7-537	~	Front	~	112 (4.81)	41 (1.6)	25.4 (1.00)	31 (1.23)
	F7-540	F7-547	F7-548-3	Concealed (thread forming)	up to 8.0 (.32)				
			F7-558-3	Concealed (thread forming)	8.1 - 17.5 (.32 - .69)				
Medium	F7-630	F7-537	~	Front	~	167 (6.6)	72 (2.83)	32 (1.25)	29 (1.13)
	F7-640	F7-547	F7-548-3	Concealed (thread forming)	up to 8.0 (.32)				
			F7-558-3	Concealed (thread forming)	8.1 - 17.5 (.32 - .69)				
Large	F7-730	F7-537	~	Front	~	221 (8.7)	117 (4.6)	32 (1.25)	29 (1.13)
	F7-740	F7-547	F7-548-3	Concealed (thread forming)	up to 8.0 (.32)				
			F7-558-3	Concealed (thread forming)	8.1 - 17.5 (.32 - .69)				

